

MN@SEC 2019



Автомашини хакердах техник болон сүүлийн үеийн тренд

Кибер аюулгүй байдлын судлаач Д.Батэлзий

CAN Протокол REVERSE ENGINEERING - Энгийн аргачилал

1. Бодит үйдэлийг CAN ID тай холбох
2. CAN сигналын бит болон уртыг тодорхойлох
3. Өсөлт болон офсетыг тодорхойлох

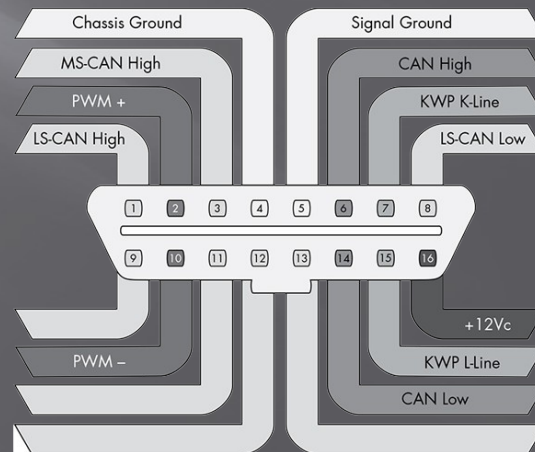
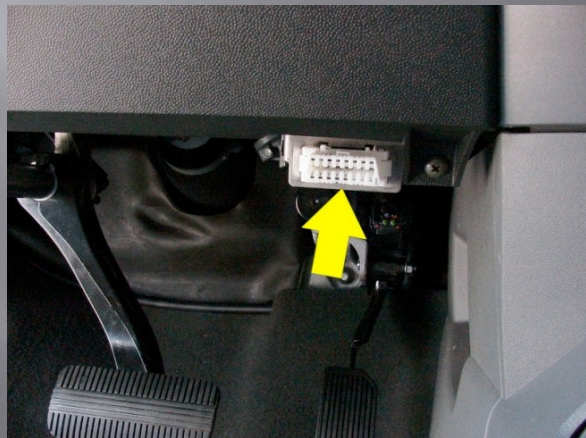

- Машины удирдлагын системийн сул талууд
- CAN протоколын энгийн адаптер болон Wireshark Cansniff Candum

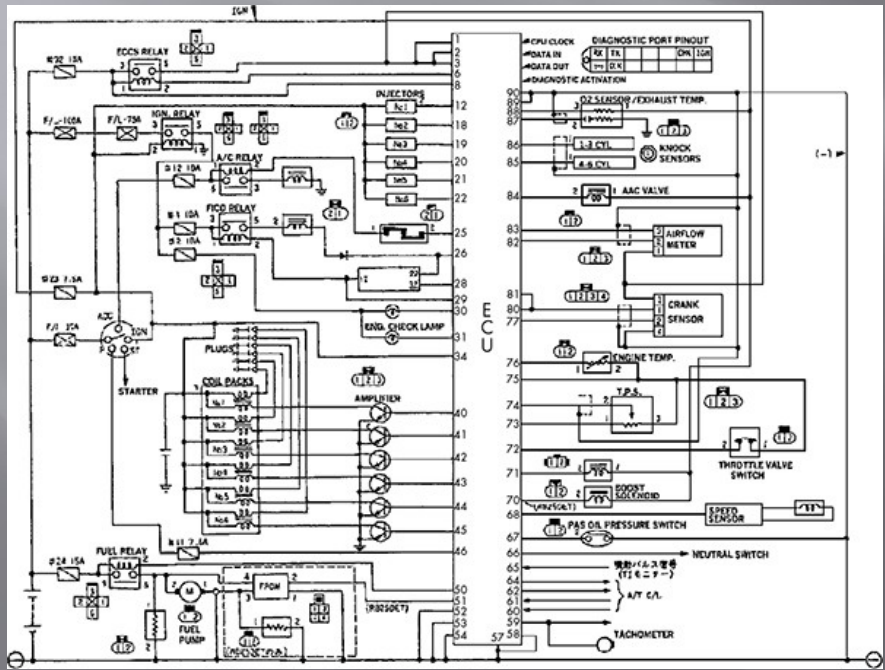

CAN Live IDs

Hide	Count	Frame No.	Time (s)	Period Time (s)	CAN ID	D0	D1	D2	D3	D4	D5	D6	D7	Frame No. (Last change)	Time (Last change) (s)
<input type="checkbox"/>	134	12055	13.362000	0.100000	488	75	65	70	00	18	8e	17	45	11965	13.362000
<input type="checkbox"/>	135	12073	13.380000	0.099000	50e	00	00	00	84	00	00	ff	0d	11984	13.380000
<input type="checkbox"/>	673	12134	13.453000	0.020000	30d	20	b0	20	b0	20	a3	20	ad	12115	13.453000
<input type="checkbox"/>	14	11836	13.116000	0.999000	552	11	52	e0	3c	00	00	00	00	10934	13.116000
<input type="checkbox"/>	673	12135	13.453000	0.020000	34d	00	03	fa	fa	00	8c	00	ff	12116	13.453000
<input type="checkbox"/>	1346	12142	13.456000	0.010000	305	00	3c	00	07	05	00	00	00	12131	13.456000
<input type="checkbox"/>	336	12117	13.433000	0.040000	38d	20	ac	53	3f	af	57	00	00	12081	13.433000
<input type="checkbox"/>	1346	12136	13.453000	0.010000	3cd	00	80	00	01	00	22	60	00	12127	13.453000
<input type="checkbox"/>	269	12108	13.420000	0.050000	432	81	52	48	fe	00	00	00	00	12063	13.420000
<input type="checkbox"/>	135	12122	13.435000	0.100000	612	ff	23	01	1c	00	00	47	00	12031	13.435000
<input type="checkbox"/>	134	12056	13.363000	0.101000	588	ff	fe	01	6c	ff	54	80	00	11966	13.363000
<input type="checkbox"/>	13	11359	12.592000	0.998000	792	03	61	8e	ff	ff	ff	00	00	10463	12.592000
<input type="checkbox"/>	673	12137	13.454000	0.020000	40d	4b	4c	97	78	8c	5a	03	0d	12119	13.454000
<input type="checkbox"/>	135	12098	13.410000	0.100000	495	ff	00	00	39	00	ff	ff	00	12006	13.410000
<input type="checkbox"/>	1346	12132	13.448000	0.010000	208	37	80	38	1a	4c	ff	ff	3a	12125	13.448000
<input type="checkbox"/>	336	12121	13.434000	0.040000	44d	20	ac	20	89	20	6c	47	ae	12085	13.434000
<input type="checkbox"/>	1346	12139	13.454000	0.010000	2f5	ff	f2	80	00	2a	94	00	00	12128	13.454000
<input type="checkbox"/>	135	12141	13.455000	0.100000	608	02	b4	00	00	00	00	00	38	12051	13.455000
<input type="checkbox"/>	337	12130	13.446000	0.041000	468	00	ff	ff	00	00	85	02	00	12094	13.446000
<input type="checkbox"/>	13	11269	12.492000	0.998000	7e2	03	61	8e	ff	ff	ff	00	00	10371	12.492000
<input type="checkbox"/>	135	12138	13.454000	0.100000	50d	10	5f	8d	60	2a	94	00	00	12049	13.454000
<input type="checkbox"/>	674	12140	13.455000	0.019000	348	e0	3a	2c	3b	01	03	00	00	11672	12.956000
<input type="checkbox"/>	1346	12133	13.449000	0.010000	228	1a	00	1a	70	00	ff	ff	00	12126	13.449000

Машины ECU бүрэн эзэмдэхэд шаардагдах багж
ECUsim
ChipWhisperer. Scripting with Python

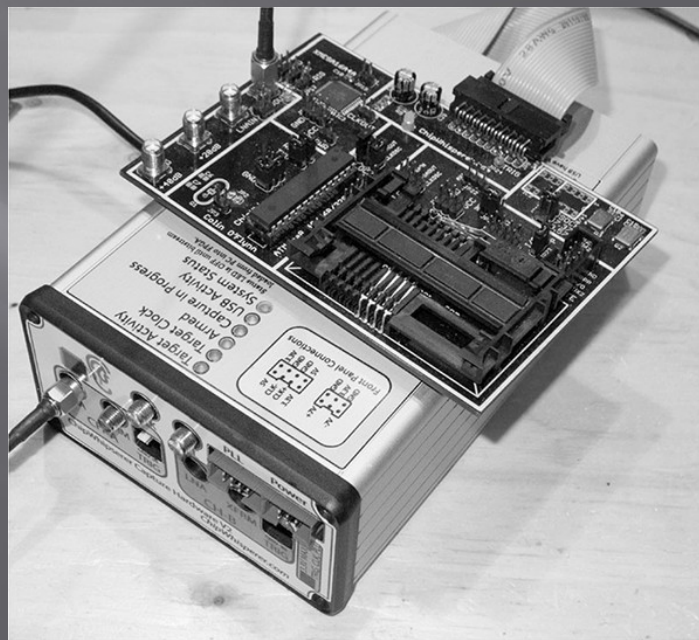
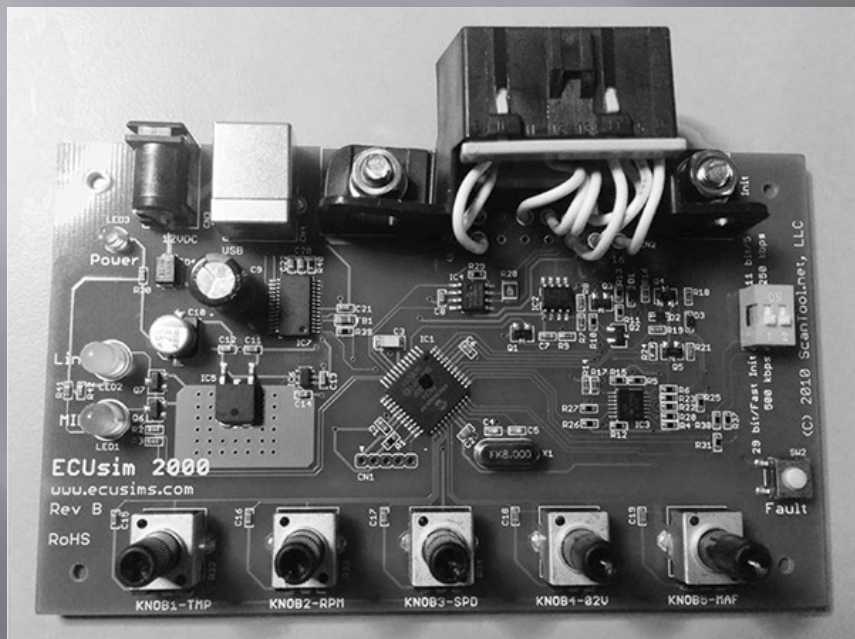

CLK1



INSTRUCTION

1 2 3 4 5 6



Attacker CLK



INSTRUCTION

1 2 3 4 5 6

Attack

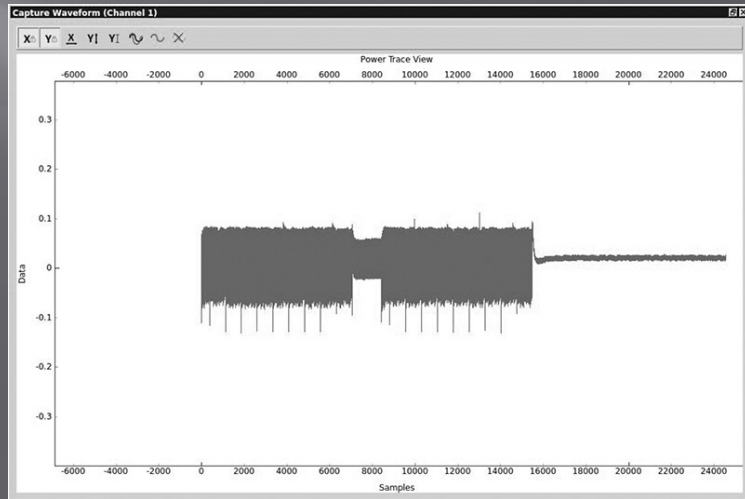
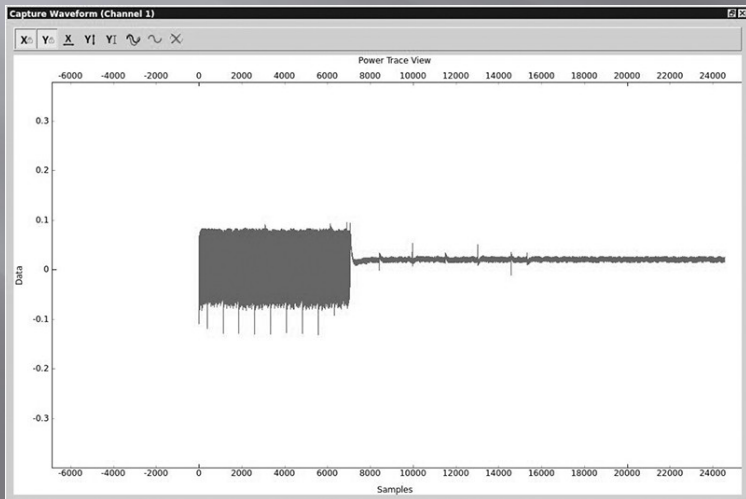

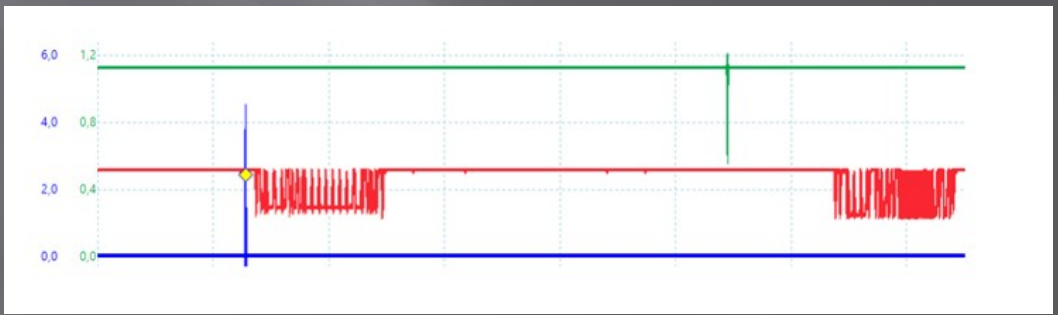
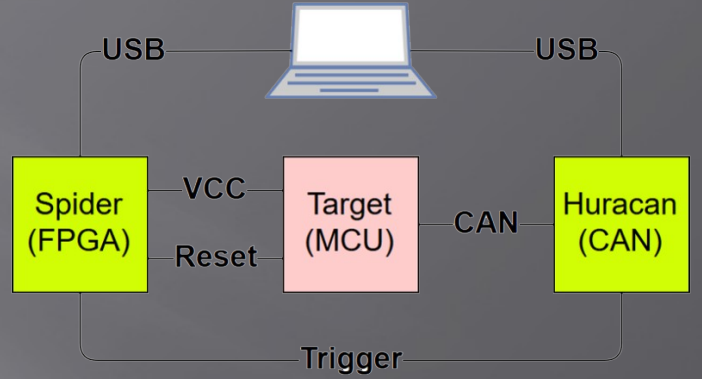
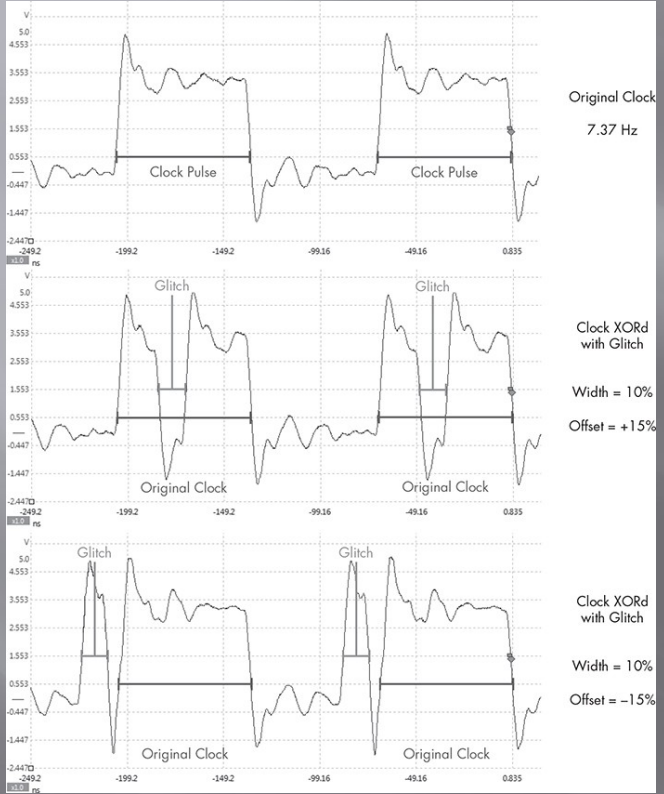



Машины системийг хакердуулсанг илчлэх аргууд

Шинээр бий болж буй технологиуд, тэдгээрийн сул талууд Jeep Cherokee vs Chris Valesek and Charlie Miller



Adaptive Cruise Control (ACC)
Lane Keeping Assist System (LKAS)

C

HOW THE SMASH HAPPENED

1 May 7: Joshua Brown (below), had engaged autopilot mode in his Model S Tesla while he drove on the highway.

2 A white articulated truck pulls across the dual carriageway in front of the Tesla. Comes to rest after hitting pylon. Tesla crashes through two fences.

LONG RANGE RADAR: Looking ahead of the car, monitoring the presence of other vehicles. It can 'see' through rain or fog.

IMAGE RECOGNITION CAMERAS: These also look ahead of the car, identifying things such as traffic signs, lane markings and pedestrians.

360 DEGREE ULTRASONIC SONAR: This all-round sensor detects everything from cars to children or pets in your blind spot.

3 The Tesla's radars and cameras did not distinguish the truck from the sky, tearing the roof off as it went under the trailer. The truck driver claims the Tesla driver was watching a Harry Potter film on the Tesla's 17inch touch screen.

RKE, Immobilizer

Hitag-2 ийн халдлага

RollJam attack. Samy Kamkar - Devcon / AppSec California

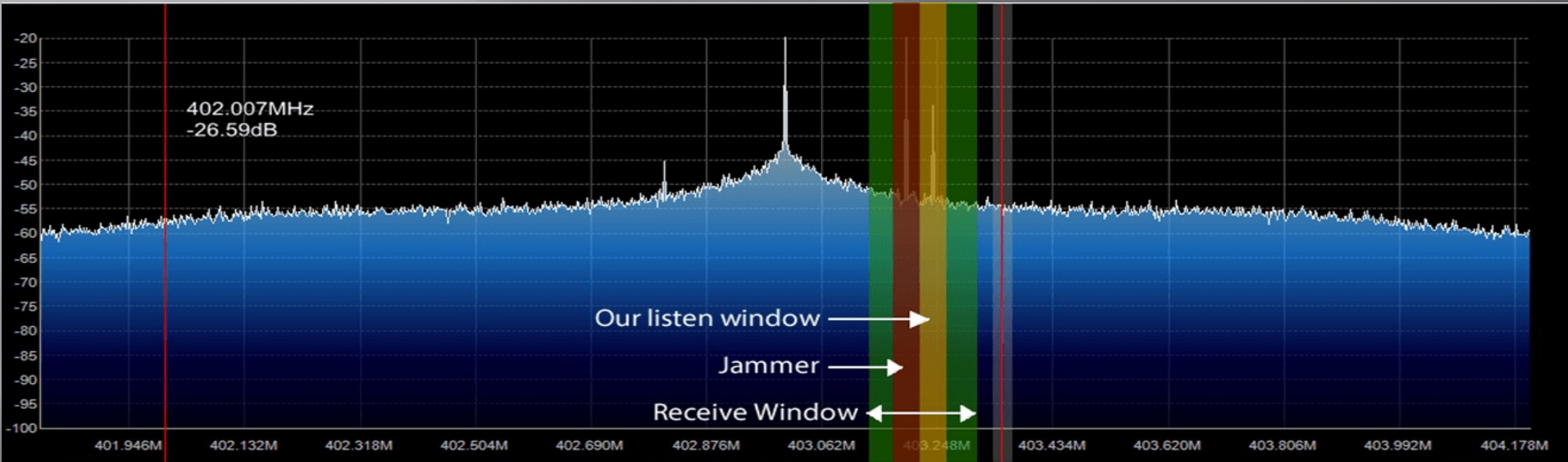

2006 Subaru Baja

2005 - 2010 Subaru Forester

2004 - 2011 Subaru Impreza

2005 - 2010 Subaru Legacy

2005 - 2010 Subaru Outback

<https://github.com/tomwimmenhove/subarufobrob>

MN@SEC 2019



Анхаарал тавьсанд баярлалаа